

SINGLE-CYLINDER 125 CC STEPPED-PISTON ENGINE FOR MOBILITY AND PORTABLE POWER GENERATION APPLICATIONS

Azhar Abdul Aziz^{1*}, Kasni Sumeru¹, Mohd Farid Muhammad Said¹, Mohd Rozi Mohd Perang¹, Henry Nasution¹

¹ *Automotive Development Centre, Faculty of Mechanical Engineering, Universiti Teknologi Malaysia, Johor 81310, Malaysia*

(Received: October 2015 / Revised: December 2015 / Accepted: January 2016)

ABSTRACT

Two-stroke engines are far simpler than four-stroke engines from a physical perspective. For a given brake output, two-stroke engines are lighter, easier to work on, and provide higher power-to-weight ratio than four-stroke engines, making them suitable for small platform applications. However, conventional two-stroke engines have a reputation for generating smoke and unburned fuel, meaning they may not meet many emissions regulations, now enforced around the world. Thus, for many decades two-stroke engines have not been favored, giving way to four-stroke engines for dominant applications, especially for mobile power-generation purposes. In the quest to improve the potential of such an engine, a group of researchers from the Automotive Development Centre (ADC), Universiti Teknologi Malaysia (UTM), has developed a 125 cc, air-cooled stepped-piston engine to demonstrate the higher power-to-weight ratio feature, apart from overcoming emission reduction. The engine is designed to mitigate the problem of mixture short circuiting, which is the major hindrance to combustion efficiency. To this end, they have incorporated a three-port stratification strategy into the engine. This paper provides an overview related to the earlier work done to integrate the necessary features and highlights some of the performance features of this unique engine design.

Keywords: Design; Engine; Prototype; Stepped-piston; Two-stroke

1. INTRODUCTION

The basic two-stroke engine operates by compressing an air–fuel mixture in both the crankcase and the cylinder, moving the mixture around using the vacuum and pressure created by the piston movement. The engine performs all functions in two strokes of the piston (down and up), and the spark plug fires each time the piston is about to approach the engine’s top dead center (TDC). Valving is provided by the motion of the piston, sliding past port openings in the cylinder wall. The above four functions must be crowded into just two piston strokes. As the piston descends on the power stroke, at roughly half-stroke it begins to uncover a large exhaust port or ports, and exhaust gas begins to leave the cylinder. Approximately a quarter-stroke later, the piston will uncover a set of fresh-charge transfer ports. Fresh air and fuel have meanwhile been drawn into the crankcase, and the descent of the piston compresses this fuel–air mixture. As the transfer ports open, this mixture begins to jet into the cylinder through the ports. The problem that arises is that even with the best-possible aiming of the transfer ports, some fresh

*Corresponding author’s email: azhar@fkm.utm.my Tel. +607-5535444, Fax. +607-5535811
Permalink/DOI: <http://dx.doi.org/10.14716/ijtech.v7i2.2974>

charge does “short-circuit” and flow directly out the exhaust. This loss of fresh charge to the exhaust is a direct consequence of having exhaust and transfer ports open at the same time. In a four-stroke engine, this is prevented by using mechanically operated valves. A good four-stroke engine needs about 220 grams of fuel to produce one horsepower for an hour. However, a well-designed two-stroke (with correctly aimed transfer ports and expansion chamber exhaust) needs roughly 280 grams of fuel per horsepower per hour. The difference of about 25 percent is due to fuel lost directly out the exhaust port (The Economist, 2010). This was acceptable before 1980 because fuel was cheap and big emissions reductions were then being achieved with cars.

Two-stroke road models were not offered after 1984 (Cycle World, 2014). A two-stroke engine especially for mobility applications was not in favor for several reasons. Firstly, they produced higher levels of hydrocarbon and carbon-monoxide exhaust emissions than four-stroke engines, and reducing those emissions cannot be readily piggybacked on all the work that had been expended by the automotive industry on car engines. Secondly, they also produced worse fuel economy due to the problem mentioned earlier. But, thirdly, and worst of all, they were perceived as “non-green,” smoke-emitting, image disasters. A conventional car engine takes four piston movements, or strokes, to go through intake, compression, combustion, and exhaust. In a two-stroke cycle, these stages are completed with just two piston movements, delivering twice as many power strokes per revolution and requiring fewer parts. But two-stroke engines tend to spew out more unburned fuel in the exhaust, which is why the four-stroke design became more common. Once thought too polluting, the two-stroke engine is making a comeback in advance of stricter fuel efficiency standards (Manufacturer of Emission Control Association, 2008).

In the last five years, many research and development (R&D) activities and investments have been made to revive the use of two-stroke engines due to their power density advantage. Several innovative solutions have been introduced to address the existing short-comings (Nomura & Nakamura, 1993; Lotus Cars, 2015; The Knee Slider, 2015). Some have proven to be successful via the integration of elements such as gasoline direct injection, electronic actuation of valves, and new materials. With these positive developments, it now seems possible for small two-stroke engines to be deployed in mobility platforms [e.g., range extender for electric vehicles (EV), unmanned aerial vehicles (UAV)] and auxiliary power units.

2. PISTON DESIGN

2.1. Early Stepped-piston Design

Bernard Hooper Engineering (BHE) was the first to develop the engine featuring a stepped-piston design (Breathe, 2015). This engine type has been the subject of extensive testing targeting industrial, automotive, marine, and aerial applications. The engines were developed in recognition of the benefits offered, but with the essential attribute of durability. This is afforded by the crankcase isolation provided by the stepped piston.

Piston mass will be higher for this type of piston design. Thus, its unique design means that for identical power cylinder bores, the stepped piston will be 20% heavier than a conventional looped scavenged two-stroke piston. This multi-section piston provides a flange stiffening effect, resulting in thinner skirt sections. The mass can be reduced by composite methods. However, the engine uses the two-stroke cycle and therefore, with the absence of load reversals, piston mass is not as critical as it is for four-stroke engines. This type of piston will provide improved load bearing and guidance resulting in low ring wear and reduced piston noise. The fresh charge and exhaust transfers are between two cylinders, as shown in Figure 1.

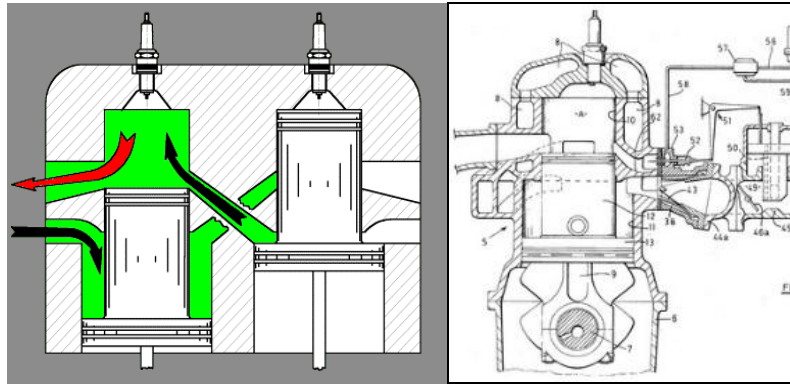

Figure 1 The early design of the stepped-piston engine (Breathe, 2015)

2.2. Modified Stepped-piston Engine

A prototype two-stroke single-cylinder engine with slight differences in the approach to mixture transfer design and piston dimensions was conceptualized. Using a three-port mixture transfer strategy, the engine was designed and developed at the Automotive Development Centre (ADC), Universiti Teknologi Malaysia (UTM). The primary objective of this work is to further explore research into how stepped-piston engines can mitigate current problems that restrict the role of conventional crankcase-scavenged two-stroke engines. This work also examines how to overcome the current problem of excessive use of lubricating oil (blend in air–fuel mixture), which results in excessive white smoke.

As mentioned earlier, stepped piston refers to the mating of two pistons to form an assembly. For this work, the main piston has an aspect ratio (bore:height) of 1:1.5. The bigger piston coupled to the main piston has an aspect ratio of 7.5:1. Each of these piston sections has a set of piston rings to prevent the air–fuel mixture from crossing over from the upper half to the lower half of the pistons or vice versa. The second piston has an aspect ratio of more than 2 and its only role is to draw in the mixture (air–fuel–lube) when the piston goes through the expansion stroke. In other words, for one cycle, the cylinder will undergo two main processes, i.e., 1) combustion/exhaust and expansion, and 2) compression and transfer, respectively. The piston motion is similar to the conventional design but without the crankcase scavenging normally associated with typical two-stroke engines. In other words, this design shortens the travelling path of the mixture into the combustion chamber. The design is shown in Figure 2.

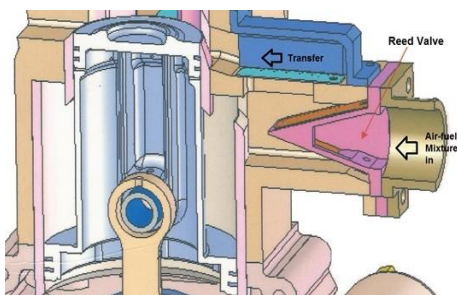

Figure 2 Engine sectional view

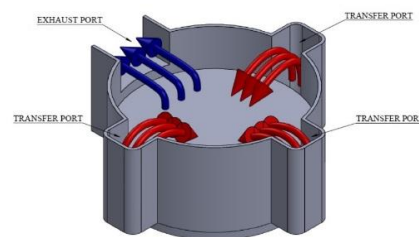

Figure 3 The cross scavenge process

The induction of the appropriate mixture for combustion occurs when the piston is in downward motion. This is primarily due to earlier combustion that takes place in the combustion chamber, resulting in gas expansion; fresh-charged mixture is drawn in to fill up the void created between the engine wall and the smaller piston. When the pressure in the void as well as in the intake is

equalized, the reed valves (shown in Figure 2) will be closed. Pressure will continue to build up as the piston assembly moves upward with assembly moves upward, the trapped air enters a flap valve (in the transfer port), and subsequently the compressed mixture will rush into the main combustion chamber. Figure 3 illustrates the employed mixing strategy.

3. DESIGN CONSIDERATIONS

There are many aspects of engineering to be considered in the design, development, and testing of a prototype. This study focuses on two prominent aspects, i.e., geometrical properties and ii) thermodynamics properties (Blair, 1996, Heywood, 1988). Both of these aspects are governed by the design specifications given in Table 1.

3.1. Geometrical Properties

The following are the basic parameters used to derive the engine reciprocating components.

Table 1 Engine design specifications

No.	Parameter	Features
1.	Cylinder type	Single-cylinder, piston ported
2.	Displacement	125 cm ³
3.	Bore × stroke	53.8 × 54 mm
4.	Compression ratio	9:1
5.	Scavenging type	Multi-port, loop scavenge
6.	Exhaust port opening/closing	93°CA ATDC/267°CA ATDC
7.	Intake port opening/closing	110°CA ATDC/250°CA ATDC
8.	Design rated power	8.5 kW@6500 rpm
9.	Ignition timing	-20°CA BTDC
10.	Lubrication system	Crankcase – splash type, Piston skirt – lube in air–fuel mixture

i. Compression ratio, rc :

$$rc = \frac{\text{max. cylinder volume}}{\text{min. cylinder volume}} = \frac{V_{\text{swept}} + V_{\text{clearance}}}{V_{\text{clearance}}} \quad (1)$$

where V_{swept} and $V_{\text{clearance}}$ are the swept and clearance volume of the engine.

ii. Bore-to-stroke ratio, R_{bs} :

$$R_{bs} = \frac{B}{L} \quad (2)$$

where B is the bore and L is the stroke.

iii. Connecting rod length to crank radius ratio:

$$R = l/a \quad (3)$$

where $l = 2a$ is the connecting rod length and a is the crank radius.

iv. Cylinder volume (V) at any crank position θ :

$$V = V_{\text{clearance}} + (\pi B^2/4)(l + a - s) \quad (4)$$

where s is the distance between the piston pin location and the center of the crankshaft, at engine crank angle θ . Calculating the instantaneous volume will assist in the computation of the heat-release calculation.

v. Combustion chamber surface area (A):

$$A = A_{\text{ch}} + A_{\text{p}} + \pi B(l + a - s) \quad (5)$$

where A_{ch} is the cylinder head surface area and A_{p} is the piston surface area. The significance of calculating the surface area is in the computation for heat transfer, leading towards the design of the cylinder wall.

vi. Specific weight:

$$\text{Specific weight} = \frac{\text{Engine weight}}{\text{rated power}} \quad (6)$$

The current trend is to produce high specific weight specifications, especially for mobile applications. For this exercise, the research group targeted the specific weight not to exceed 4.0.

3.2. Thermodynamic Properties

The thermodynamic aspects were also given due consideration in deriving the geometrical properties. Among the parameters that were taken into considerations are the following:

i. *Delivery ratio*: The delivery ratio, DR , defines the mass of air supplied during the scavenged period as a function of a reference mass, m_{dref} , i.e., mass required to fill the swept volume under atmospheric conditions:

$$DR = m_{\text{as}}/m_{\text{dref}} \quad (7)$$

ii. *Scavenging ratio*: The scavenging ratio, SR , defines the mass of air supplied during the scavenged period as a function of a reference mass, m_{sref} , i.e., the mass that is able to occupy the entire cylinder volume under atmospheric conditions. It is defined as:

$$SR = m_{\text{as}}/m_{\text{sref}} \quad (8)$$

iii. *Scavenging efficiency*: Scavenging efficiency, SE , is the mass of delivered air that has been trapped, m_{tas} , in relation to the total mass of charge, m_{tr} , retained during exhaust port closure. The trapped charge is made up of the fresh charge trapped, m_{tas} , exhaust gas, m_{ex} , and residual gas from the previous cycle, m_{ar} :

$$SE = m_{\text{tas}}/(m_{\text{tas}} + m_{\text{ex}} + m_{\text{ar}}) \quad (9)$$

iv. *Trapping efficiency*: Trapping efficiency, TE , is the capture ratio of the mass of delivered air that has been trapped, m_{tas} , to that supplied, m_{as} :

$$TE = m_{\text{tas}}/m_{\text{as}} = SE/SR \quad (10)$$

- v. *Charging efficiency*: Charging efficiency, CE , is the ratio of the filling of the cylinder with air to that of filling the same cylinder perfectly with air at the onset of the compression stroke. It is written as:

$$CE = m_{tas}/m_{sref} = TE \times SR \quad (10)$$

- vi. *Air-fuel ratio*: This is an equally important parameter, which is the ratio of the mass of air intake, m_{air} to that of the fuel intake, m_{fuel} , per unit time:

$$AFR = m_{air}/m_{fuel} \quad (11)$$

- vii. *Heat release during the burning process*: This is a heat quantity released from the combustion of fuel induced and burned and is designated as Q_R . It is calculated as:

$$QR = \eta_c \times m_{ef} \times LCV \quad (12)$$

where η_c is combustion efficiency and LCV is the fuel's low calorific value.

Along with the above parameters, heat transfer analysis is also a crucial aspect investigated in optimizing development work on the engine. Heat transfer will affect engine performance and emissions. The engine specific power and efficiency will be effected by the magnitude of the engine heat transfer from the combustion chamber to the reciprocating mechanism, cylinder head, and wall. Under this development project, heat transfer between unburned charge and the chamber wall was carefully investigated whereby the optimum design was derived to overcome engine knock.

4. PERFORMANCE SIMULATION

Instead of testing every operating point on a dynamometer, a computer model was used to simulate the engine, created using Gamma Technology's GT-PowerTM (v.6.0) software suite. With GT-Power, the physical dimensions of the complete powertrain system must be entered. The process of creating a GT-Power model begins with dividing the engine into its components. The major components are the carburetor, throttle, reed valve, intake manifold, engine, and exhaust system. For the intake manifold, the most important aspect is to model all of the pipe bends and flow splits. The software has preset components for straight pipes, bent pipes, and flow splits. Each component is defined by several parameters such as discharge coefficient, cross sectional area, and length.

In addition to the physical properties of the engine, a combustion model must be entered. The flow dynamics created by the opening and closing of the intake and exhaust port are complex. Therefore, it is difficult to replicate the intricate mixing action of fuel using a simple model. Combustion is largely dependent upon the mixing inside the cylinders and the local air-fuel ratio around the spark plug. Therefore, the in-cylinder flows are very important. Although it is possible to create a model that truly captures all of the fluid motion, the model would take a significantly longer time to converge to a solution. A long convergence time is unfavorable, so a combustion model is used, reducing the simulation time and accounting for the in-cylinder fluid motion. The one-dimensional (1D) model for this engine, generalizing the properties of each of components, is shown in Figure 4.

The $P-\theta$ and $P-V$ plots together with the heat release profiles were the essential tools in the optimization of the reed valve, intake passage, transfer, and exhaust ports. These parameters assist in the optimization of the combustion chamber configuration. Figure. 5, 6, and 7 illustrate

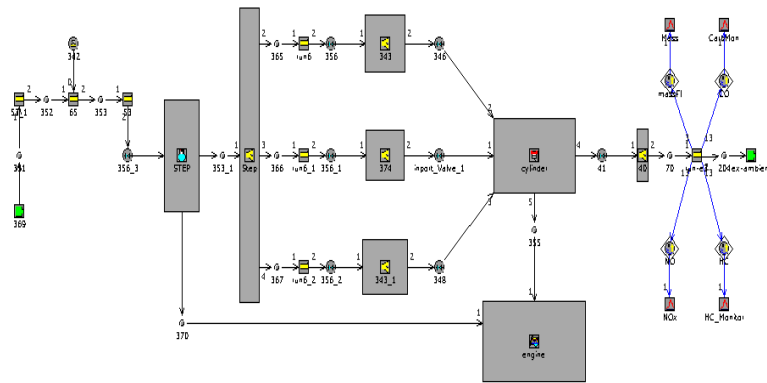

Figure 4 GT-Power 1D model of stepped-piston engine

the pressure and rate of heat release profiles generated by GT-Power based on the properties of the engine components and geometry. These data generate peak cylinder pressures between 1500 and 6500 rpm. This speed range has been identified to generate peak torque for the designed engine. Early indications also show that rapid rate of heat release will occur for the lower speed engine operation. As the speed is increased, the rate of heat release will be lowered, as shown in Figure 7.

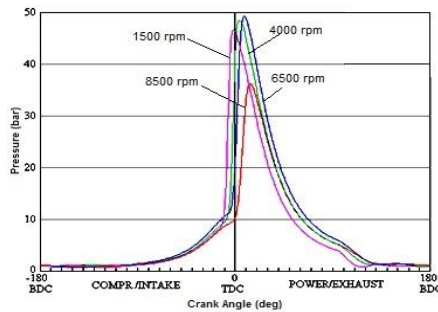

Figure 5 Pressure vs. crank angle position showing the pressure profile at various speeds subjected to full load

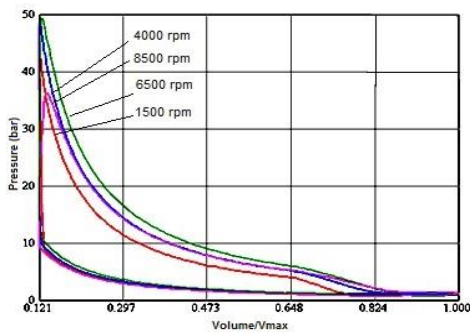

Figure 6 Pressure vs. swept volume position showing the pressure profile at various speeds subjected to full load

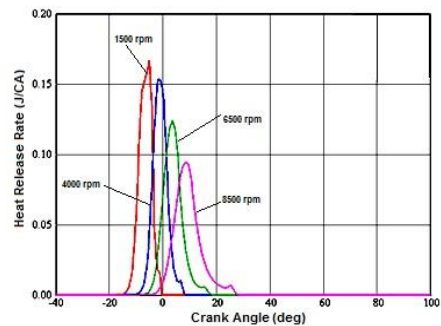

Figure 7. Heat release rate taken for the selected speeds at maximum load

5. ENGINE DEVELOPMENT WORK

There are 98 components and parts that constitute the engine as a whole (see Figure 8). They are classified as critical and non-critical, whereby some are standard items (off-the-shelf),

which can be obtained from suppliers. The non-standard items are unique to the engine and they differentiate the engine from the ordinary crankcase scavenged type. The reciprocating parts (piston, connecting rod, and crankshaft) were classified as critical. This was followed by the cylinder liner, cylinder head, main body, center body (component between cylinder head and the main body), and flywheel. The critical and less-critical components were manufactured using local expertise and services. A summary of the type of materials and the process involved is given in Table 2.

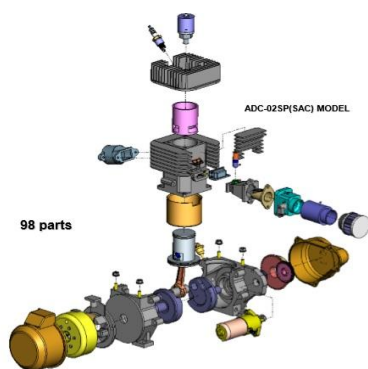

Figure 8 The exploded view

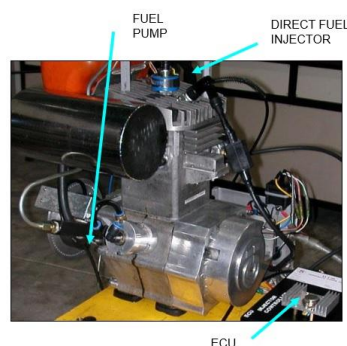

Figure 9 The 125 cc stepped-piston engine

Table 2 Critical engine components

Component	Material	Process
Piston	Aluminum alloy	Casting + dehorning + hardening + machining + grinding
Connecting rod	Steel alloy (T6-2024)	Drop forged + machining
Crankshaft Flywheel	Cast iron	Green sand mold casting
Cylinder head	Aluminum alloy (Al-10mg)	Green sand mold casting
Center body	Aluminum alloy (Al-10mg)	Green sand mold casting
Crankcase	Aluminum alloy (319 type)	Green sand mold casting

Upon completion of fabrication, these components were assembled. The engine was then fitted with the fuel as well as the ignition systems. The completely assembled engine is shown in Figure 9.

6. LABORATORY TRIAL WORK

The laboratory investigation was done in accordance with the SAE J1349 standard for engine tests. The aim was to establish the best possible performance, under typical operating conditions. A 30kW eddy-current dynamometer (Magtrol, WB30) was used in conjunction with a volumetric fuel flow meter (Ono-Sokki, FP-213s) and a portable emission analyzer (Autocheck 982). The test was done with full open throttle, where the throttle is increased slowly until the engine produces the maximum torque. The engine speed is set to a constant value at the dynamometer controller. The dynamometer will control the engine's speed according to the set value. The M-TEST™ program (control and data acquisition software) was used to record the values of speed, torque, and power, as well as the time of the test. Average value is taken for the speed, torque, and power produced by the engine at the setting speed. The setting speed value at the dynamometer and the speed produced by the engine are not the same. The values constantly fluctuate depending on speed and ambient conditions. To overcome this irregularity, the attenuating PID (proportional gain, integral and derivative) setting of the dynamometer controller was made for best system response.

For all engine tests, the maximum speed allowed was limited to 5500 rpm, solely for the safety of operators and researchers on site. Figure 10 is a compilation of corrected experimental results, taken for a number of cycles, showing the brake power, the brake torque, and the specific fuel consumption. Figure 10 depicts the three major constituents of the emission, also at maximum load settings. The brake power registered at 5500 rpm was 6.45 kW, maximum torque was registered at 4000 rpm, and the best specific fuel consumption was at 255 g/kWh at 3500 rpm.

Figure 11 illustrates the results showing the tailpipe emission concentrations (g/kWh) for the engine test under similar conditions to those in Figure 9. Here the trend for CO₂, CO, and HC are shown in descending order with respect to the speed increment. When the speed is increased, the reduction of these three gas species is apparent. In general, the concentration of CO₂ ranges from 100 to 500 g/kWh, CO from 100 to 500 g/kWh, and HC from 20 to 100 g/kWh. These values are within the permissible level of the US Environmental Protection Agency (EPA) for off-highway two-stroke engine specifications (EPA Regulatory Announcement, 2002).

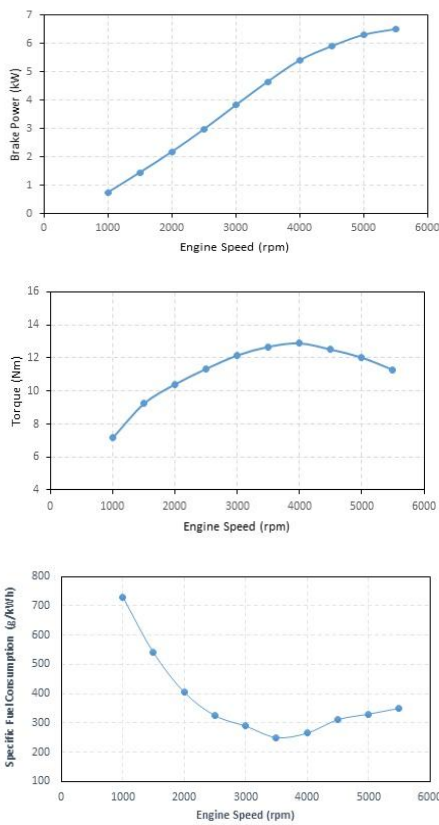

Figure 10 Engine and fuel consumption data at maximum load

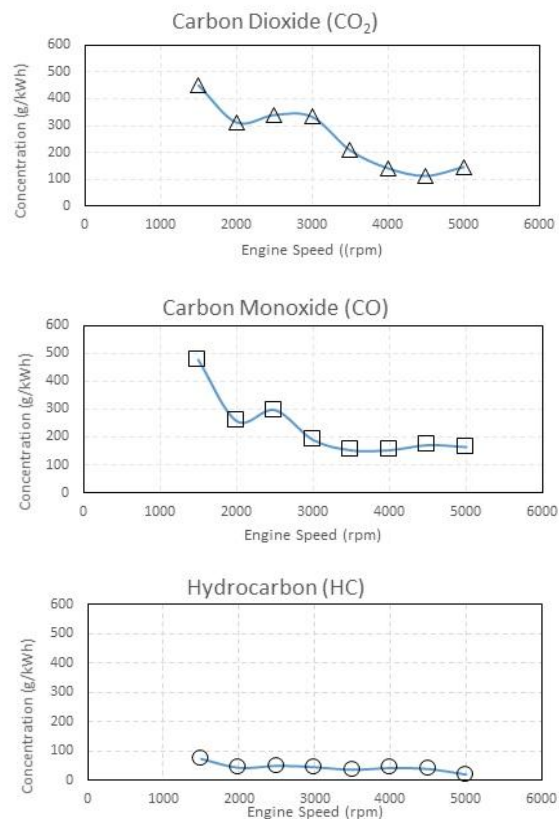

Figure 11 The tailpipe measurement for CO₂, CO, and HC at maximum load condition

7. CONCLUSION

The aspiration of producing an air-cooled, two-stroke engine of a stepped-piston type, with potential of generating 8.5 kW at 6500 rpm, has been realized, from design to prototyping. Design work starts with the desired specifications and is followed by performance simulation using GT-PowerTM to model the engine. Promising indications from the simulation results

warrant the development work to commence for components, piston, cylinder head, and the main body of the engine.

Once the components have been produced, fuel and ignition systems were fit to the prototype. Experimental engine trials were subsequently carried out using an eddy-current dynamometer facility to measure brake torque, power, fuel consumption, and selected emission constituents up to 5500 rpm. The trial produced engine output of 6.5 kW at this safe limit of the engine trial, with the best specific fuel consumption registered as 250 gram/kWh at 3500 rpm. Emission levels are acceptable and within limits specified by the EPA for the small engine category.

However, there are still some short-circuiting problems with regard to combustion gas, calling for further refinement of the trapping efficiency. The prototype as a whole has met early design expectations in terms of output in the mid-speed range. Work is now underway to mitigate this problem by incorporating an innovative rotary valve to improve the trapping mixture capability of the engine. This will lead to further combustion improvement.

8. ACKNOWLEDGEMENT

This project was funded by Malaysia's Ministry of Science, Technology and Innovation (MOSTI, UTM Ref. Vote No.: R.J130000.7909.4S111). The authors would like to acknowledge with utmost gratitude the effort made by researchers, technicians and graduate students of UTM, who have relentlessly assisted in making this project possible.

9. REFERENCES

- Blair, G.P., 1996. *Design and Simulation of Two-Stroke Engines*, SAE Publication
- Breathe, 2015. *The Stepped Piston Engine*. Available online at: www.breathe.com
- Cycle World, 2014. *Why No Modern Two-Stroke Streetbikes*. Available online at: www.cycleworld.com
- Heywood, J.B., 1998. *Internal Combustion Engine Fundamentals*, McGraw Hill, New York City, New York, USA
- Lotus Cars, 2015. Omnivore Research Engine, Case study omnivore research engine, *Lotus Engineering News*. Available online at: www.lotuscars.com
- Manufacturer of Emission Control Association, 2008. *Report on Emission Control of Two- and Three-Wheel Vehicles Washington, D.C., USA*.
- Nomura, K., Nakamura, N., 1993, Development of a New Generation Two-stroke Engine with Poppet-valve: Toyota S-2 Engine. *A New Generation of Two-Stroke Engines for the Future, Edition Technip*, pp. 53–62
- The Economist, 2010. *The Difference Engine: Twice the Bang for the Buck*. The Economist Group, London, United Kingdom
- TheKneeSlider, 2015. *Eco Motors OPOC Two Stroke Engines – Opposed Piston Opposed Cylinder*, The Knee-slider. Available online at: thekneeslider.com
- US EPA, 2002. *Emission Standards for New Non-road Engines*, EPA Regulatory Announcement, EPA420-F-02-03