

## DISINFECTION OF BACTERIA *ESCHERICHIA COLI* USING HYDRODYNAMIC CAVITATION

Eva Fathul Karamah<sup>1\*</sup>, Indika Sunarko<sup>1</sup>

<sup>1</sup>*Chemical Engineering Department, Faculty of Engineering, Universitas Indonesia, Kampus Baru UI Depok, 16424, Indonesia*

(Received: February 2013 / Revised: June 2013 / Accepted: June 2013)

### ABSTRACT

This study brings out a disinfection process of bacteria *Escherichia coli* using a hydrodynamic cavitation method. The method used different contactors, orifice plate and venturi injector. The experiment result shows that an orifice plate with initial concentration of  $10^4$  CFU/mL has decreased into zero CFU/mL after 20 minutes, while venturi injector has decreased into zero CFU/mL after 30 minutes. The orifice plate gave a better, more effective and faster disinfection than the venturi injector.

**Keywords:** Disinfection; *Escherichia coli*; Hydrodynamic cavitation; Orifice plate; Venturi injector

### 1. INTRODUCTION

One of the problems that arises in the provision of clean water supply in Indonesia, especially in Jakarta is the contamination of ground water by bacteria *Escherichia coli* (*E.coli*). Some sources state that the vast area of ground water in Jakarta is contaminated by *E.coli* reached up to 65%–95% (Firmansyah, 2009). Around 80%–90% of the vast area of groundwater in Jakarta is contaminated by *E.coli*.

The common methods of disinfection of bacteria are chlorination and ozonation. The chlorination has several disadvantages including the formation of carcinogenic disinfection by-products and appearance of taste and odor problems in processed water. However, it is relatively cheap and easy to use as long as accompanied by careful control of dosing which increases the maintenance costs (Mezule et al., 2009).

Ozonation is an the attractive alternative of disinfection due to the reactive oxidation power of ozone and its ability to kill bacteria and pathogens without producing Tri Halo Methane (THM) (Sururi et al., 2008). Ozone is also able to deactivate pathogenic microorganisms that are resistant to conventional disinfectants (chlorine, chlorine dioxide) such as *Cryptosporidium parvum* and *Giardia* (Von Gunten, 2003a). However, ozone solubility in water is relatively low and it is an unstable gas which quickly disappears in a few minutes in the water. So it does not leave a residual disinfectant (residue), which causes the water to be easily re-contaminated in a short time (Von Gunten, 2003b). Moreover, it can produce bromate compounds, a carcinogenic and mutagenic compound that increases the toxicity of the effluent. The process also requires large electrical energy (USEPA, 2009). Other potential method used for disinfection is cavitation. Cavitation is defined as the phenomena of the formation, growth and subsequent collapse of microbubbles or cavities occurring in an extremely small interval of time (milliseconds) releasing large magnitudes of energy (Gogate & Pandit, 2001).

---

\* Corresponding author's email: [eva@che.ui.ac.id](mailto:eva@che.ui.ac.id), Tel. +62-21-7863516 Ext. 6216, Fax. +62-21-7863515  
Permalink/DOI: <http://dx.doi.org/10.14716/ijtech.v5i1.116>

Microbubbles are distinguished by having a diameter less than 50  $\mu\text{m}$ , while macrobubbles (conventional bubbles) have a diameter in millimeters. The extreme condition of cavitation generates a high intensity pressure which affects the cell and microorganism viability (Arrojo et al., 2008). Generally the cavitation method for disinfection of bacteria is ultrasonic (acoustic) cavitation and hydrodynamic cavitation. On acoustic cavitation the pressure variations in the liquid are effected by sound waves, usually ultrasound (16 KHz–100 MHz). Hydrodynamic cavitation is produced by pressure variations, which is obtained by changing the geometry of the system, thus creating velocity variation. This can be achieved in flows through orifice, venturi etc. (Jyoti & Pandit, 2003).

Hydrodynamic cavitation has many advantages, such as the reactions that require moderately rigorous conditions can be carried out easily under ambient conditions; it is one of the cheapest and most energy efficient methods of cavitation generation, simple, very low maintenance; and the scale-up is relatively easy (Jyoti & Pandit, 2003). Therefore, this method can be used for further development of ultrasonic cavitation which requires more energy and at a very large cost.

Research by Mezule et al. (2009) about the effect of water disinfection on the survival of *E.coli* cells using hydrodynamic cavitation concluded that the method is able to kill 75% of *E.coli* bacteria and it is very promising for water disinfection.

Several parameters which affect the performance of hydrodynamic cavitation in disinfection process are the type of contactor, time and initial impact of the *E.coli* concentration (Sivakumar & Pandit, 2002). This study performed disinfection of *E.coli* by hydrodynamic cavitation using two conditions, one which is using the orifice plate and the other using a venturi injector. Disinfection with both contactors was carried out to determine which method of disinfection is most effective in deactivating pathogenic microorganisms.

## **2. METHODOLOGY/ EXPERIMENTAL**

### **2.1. Bacterial Strains and Culture Conditions**

*E.coli* ATCC 9637 was inoculated into 1% of BPW (Buffered Peptone Water) overnight at 4°C. It resulted a  $10^8$  CFU/mL of pure *E.coli* culture.

### **2.2. Experimental Set-up**

The scheme of experimental set-up is depicted in Figure 1. Cavitation for this experiment is generated by an orifice plate and a venturi injector. An orifice plate was designed with 17 holes and the diameter for each one of the holes is 1 mm, as can be seen in Figure 2. The plate is made up of stainless steel (SS 316) and the diameter of plate is 38 mm (Sawant et. al., 2008). A venturi injector is a Mazzei type 384. The pump in the system is a centrifugal pump with a capacity of 48 LPM.

### **2.3. Injection of Culture**

The feed water was made by dissolving 60 mL of pure culture into 6 liters of mineral water. This was adjusted for the different initial concentration.

### **2.4. Disinfection Experiment**

The experiment of disinfection used three configurations i.e.: a pipe without contactor, an orifice plate and a venturi injector. With variations of the initial concentration are  $10^6$ CFU/mL,  $10^5$  CFU/mL, and  $10^4$  CFU/mL. On every experiment, inlet pressure, outlet pressure, flow rate and concentration of *E.coli* were measured every 15 minutes.

### **2.5. Analysis of Bacteria**

The concentration of bacteria was analyzed by the TPC (total plate count) method with CCA (chromocult coliform agar) as the medium. The agar medium was incubated for at least 24

hours at 37°C and placed in the inverted position. After 24 hours, the purple color of *E.coli* bacteria colonies is apparent and a pink color of coliform bacteria colonies were observed as shown in Figure 3.

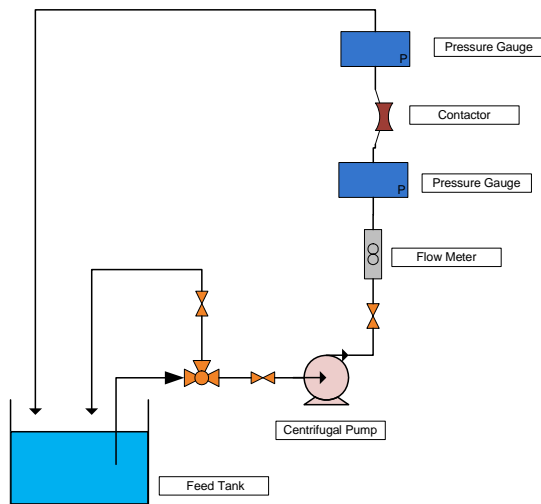

Figure 1 Experimental set-up

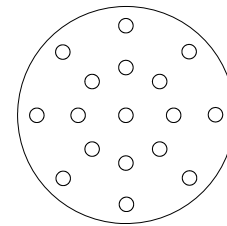

Figure 2 Orifice plate design

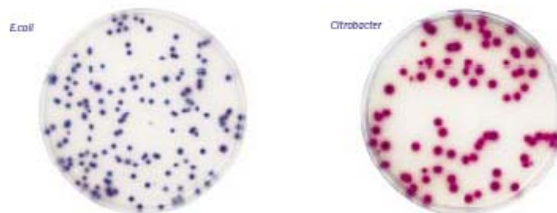

Figure 3 The different color of CCA

### 3. RESULTS AND DISCUSSION

#### 3.1. Disinfection of Bacteri *E.coli* without a Contactor

As a preliminary experiment, to convince the research team whether disinfection can occur only because of the factors related to the circulation of the liquid, the flow in the pump and the impact of the fittings, the disinfection experiment was carried out without a contactor as a cavitation generator.

In this experiment, the operating conditions are the same as the operating conditions with a contactor. The flow rate was set to 13 LPM and the initial concentration of bacteria was  $10^4$  CFU/mL.

The result from this study is shown in Table 1. The initial concentration of  $1 \times 10^4$  cfu/ml has decreased into  $3.8 \times 10^3$  cfu/ml in 60 minutes. The result shows that disinfection of *E.coli* can occur without a cavitation generator. However, the result was not optimum due to the high final concentration of *E.coli*,  $3.8 \times 10^3$  CFU/mL or 0.38 portion of the bacteria were still contaminating the feed water.

The disinfection may occur for several reasons. During the process, the liquid circulation in the pipe generated turbulence, and potentially decreased the bacteria count. In addition, the

temperature in the water was increased up to 40°C, which can reduce the bacteria. Besides that, the cavitation possibly occurred in the pump and potentially decreased the bacteria.

Table 1 Data of disinfection without using contactor

Time (minutes)	<i>E.coli</i> Concentration (CFU/mL)	Temperature (°C)
0	$1.0 \times 10^4$	25.0
15	$6.4 \times 10^3$	31.4
30	$6.0 \times 10^3$	35.4
45	$4.7 \times 10^3$	38.1
60	$3.8 \times 10^3$	40.0

### 3.2. Disinfection of Bacteri *E.coli* using an Orifice Plate

This experiment used a variation of initial concentration of *E.coli*,  $10^6$  CFU/mL,  $10^5$  CFU/mL, and  $10^4$  CFU/mL to determine the effect of the concentration of *E.coli* with the ratio  $C/C_0$ . The result of this experiment is shown in Table 2.

Table 2 *E.coli* concentration during disinfection using an orifice plate

Time (minutes)	<i>E.coli</i> Concentration (CFU/mL)	<i>E.coli</i> Concentration (CFU/mL)	<i>E.coli</i> Concentration (CFU/mL)
	$C_0 = 10^6$ CFU/mL	$C_0 = 10^5$ CFU/mL	$C_0 = 10^4$ CFU/mL
0	$2.6 \times 10^6$	$1.0 \times 10^5$	$1.0 \times 10^4$
15	$1.31 \times 10^6$	$4.0 \times 10^4$	15
30	$4.5 \times 10^5$	$1.0 \times 10^3$	0
45	$3.9 \times 10^3$	0	0
60	$2.8 \times 10^3$	0	0

It is shown that the initial concentration of *E.coli* affects the result of disinfection. At the same disinfection time, the higher the initial concentration of bacteria, the lower the final concentration. As shown in Table 2, the extent of disinfection ( $C/C_0$ ) for the three initial concentrations is in the following order: initial concentration of  $10^6$  CFU/mL >  $10^5$  CFU/mL >  $10^4$  CFU/mL. At the initial concentration of  $10^6$  CFU/mL, the final value of  $C/C_0$  of 0.001 is obtained in 60 minutes, whereas the value of  $C/C_0$  of 0 is obtained at the initial concentration of  $10^5$  CFU/mL and  $10^4$  CFU/mL in 45 minutes and 20 minutes, respectively.

The mechanism of disinfection of bacteria *E.coli* using hydrodynamic cavitation is a combination of mechanical effect, chemical effect and the heat effect (Save et al., 1997).

The mechanical effect in the disruption of the *E.coli* cells has several mechanisms. Based on their experiments, Engler and Robinson stated that the impingement of a high velocity jet of suspended cells on a stationary surface is necessary for effective disruption of cell walls (Save et al., 1997). The characteristic of turbulence can be observed by calculating of the Reynolds number.

From the calculation of the Reynolds number, it earned the value around 15,000-16,000. So it can be concluded that the flow is turbulence, thus turbulence made it possible to result in a disinfection of bacteria in the pipeline. Another mechanism of disinfection is stated by Doulah. Doulah explained the mechanism of cavitationaly induced cell disruption based on Kolmogoroff's theory of isotropic turbulence and on analysis of fluid eddies created due to the collapse of the cavity. Those fluid eddies that are smaller than the dimension of cell will impart motions of various intensities to them, and when kinetic energy content of the cell exceeds the wall strength, the cell disintegrates. Because of the turbulence flow, the fluid eddies must have been formed in the stream, and the effect of these eddies enable them to disinfect the bacteria. The main cause for cell disruption, based on the experiment of Save et.al is shock wave i.e. the pressure impulse produced from the collapsing cavities (Save et al., 1997).

The chemical effect of hydrodynamic cavitation occurs due to the formation of free radicals from the burst of microbubbles. During the process of destruction of microbubbles in the water, water vapors trapped inside the bubble experienced pyrolysis reactions which can produce highly reactive radicals such as the hydroxyl radical as explained in Equation (1). OH radicals can react in the gas phase or in combination in cooler areas such as gas-liquid interphase and/or bulk phase solution to produce hydrogen peroxide and water (Equations 2 and 3) (Ince et al., 2001):



According to the research by Arrojo et al. (2008), the OH radical generation for each initial concentration is similar, therefore the disinfection with  $10^4$  CFU/mL of initial concentration would be easier to be disinfected than  $10^5$  CFU/mL of initial concentration, as well as on  $10^6$  CFU/mL of initial concentration (Arrojo et al., 2008). The OH radical generation is not enough to kill the bacteria at a higher initial concentration. Therefore, in the experiment with an orifice plate, the smaller initial concentration of *E.coli* gave better results than the higher initial concentration. In their experiment, Balasundaran and Harrison (2008) explained the mechanical and chemical effects of disinfection of *E.coli* using hydrodynamic cavitation by mechanisms as shown in Figure 4, with the following steps (Balasundaram & Harrison, 2008):

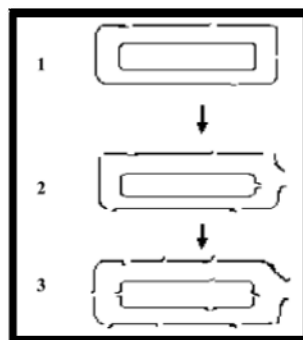

Figure 4 Mechanical and chemical mechanism of disinfection  
(Balasundaram & Harrison, 2006)

1. First stage: the mechanical effects of cavitation results in formation of pores on the outer cell wall releasing a portion of the periplasmic enzymes and proteins.

2. Second stage: the mechanical effects combined with chemical effects of cavitation can now reach the inner cytoplasmic membrane, releasing some cytoplasmic products.
3. Third stage: on sustaining the exposure of the cells to cavitation, more effects can be observed on the outer cell wall due to its greater accessibility to the cavitation than the inner membrane. Increased exposure of the *E.coli* cells to the cavitation zone weakens the cell wall due to fatigue resulting from repeated exposure to oscillating cavities and the collapse of the cavities closer to the cell wall.

The heat effect on disinfection using hydrodynamic cavitation is the increase in temperature that occurs locally up to 5000°C (Arrojo et al., 2008) which can cause the *E.coli* bacteria to die. However the exact mechanism with hydrodynamic cavitation is difficult to observe because the cavitation time is very fast. Therefore the mechanism of disinfection would occur due to a combination of several effects.

From a biological viewpoint, disinfection using hydrodynamic cavitation may occur. This is due to the thickness of the cell wall of *E.coli*. *E.coli* is a gram negative bacteria that has thinner cell walls than gram positive bacteria, which makes it possible to disinfect *E.coli* physiologically. The *E.coli* bacteria used was *E.coli* that has been grown for more than 24 hours, so it is in the dividing and diploid phase. The bacteria would be more sensitive when it has lived in extreme conditions. According to Thacker (1973), bacteria cells in the dividing phase are more susceptible to death than cells in the stationary phase. Other factors that allow the disinfection are the shape and size of *E.coli*. According to the experiments by Thacker (1973), larger cells such as dividing cells will experience greater tensile stresses than the smaller cells, and more elongated bacteria are more susceptible to cavitation effects than smaller and more compact bacteria (Gogate, 2007). The results of visualization of bacteria on a 1000 times magnification is shown in Figure 5.

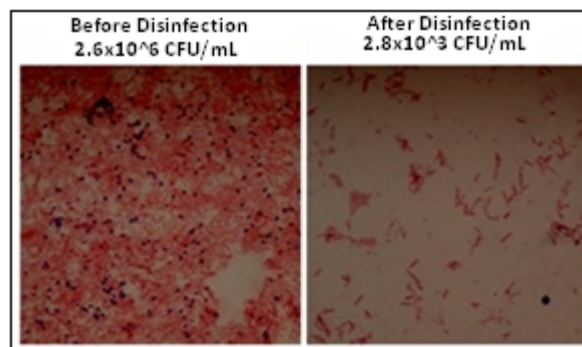

Figure 5 Visualisation of bacteria experienced disinfection using an orifice plate

### 3.3. Disinfection of Bacteria using a Venturi Injector

This experiment used the same variation of the initial concentration of *E.coli*, as in the orifice plate experiment. The result is shown in Table 3.

It is shown that the initial concentration of *E.coli* affects the result of disinfection. For the same disinfection time, the higher the initial concentration of bacteria, the lower the final concentration. The extent of disinfection ( $C/C_0$ ) for the three initial concentrations for disinfection by a venturi injector is in the same order as the value for an orifice plate disinfection. However, final values of  $C/C_0$  are different. At the initial concentration of  $10^6$  CFU/mL, the final value of  $C/C_0$  of 0.01 is obtained in 60 minutes, whereas the value of  $C/C_0$  of 0 is obtained at the initial concentration of  $10^5$  CFU/mL and  $10^4$  CFU/mL in 60 minutes and 30 minutes, respectively.

Table 3 *E.coli* concentration during disinfection using a venturi injector

Time (minutes)	<i>E.coli</i> Concentration (CFU/mL)	<i>E.coli</i> Concentration (CFU/mL)	<i>E.coli</i> Concentration (CFU/mL)
	$C_0 = 10^6$ CFU/mL	$C_0 = 10^5$ CFU/mL	$C_0 = 10^4$ CFU/mL
0	$3.0 \times 10^6$	$4.0 \times 10^5$	$1.0 \times 10^4$
15	$1.0 \times 10^6$	$9.0 \times 10^4$	$7.5 \times 10^2$
30	$5.0 \times 10^5$	$3.0 \times 10^2$	0
45	$4.0 \times 10^5$	40	0
60	$3.0 \times 10^4$	0	0

Comparison between the  $C/C_0$  value of the orifice plate and venturi injector shows that the orifice plate gave better results. For the initial concentration of  $10^6$  CFU/mL, the value of  $C/C_0$  of orifice plate at 60 minutes is smaller than is the venturi injector. For the initial concentration of  $10^5$  CFU/mL and  $10^4$  CFU/mL, the  $C/C_0$  value of 0 is reached faster for orifice plate than for the venturi injector

This difference could happen due to the difference in turbulence that occurred in the two contactors. Actually, the mechanism of disinfection is the same for both of them. The mechanism of disinfection due to mechanical effect can be estimated from the Reynolds Number. The calculated value of Re on the flow for the venturi injector is around 9000. So the type of the flow is related to turbulence, and the disinfection of bacteria is possibly occurred. However, the Reynolds number in the venturi injector is smaller than that of the orifice plate. The smaller turbulence is directly proportional to the magnitude of pressure and velocity in the pipe, and the generated eddies flow. This means that the venturi injector provides lower impact in disinfection of *E.coli* than the orifice plate. The number of the eddies flow generated would be smaller, that gives lower interference to the cell wall of bacteria. The results of visualization of bacteria on a 1000 times magnification are shown in Figure 6.

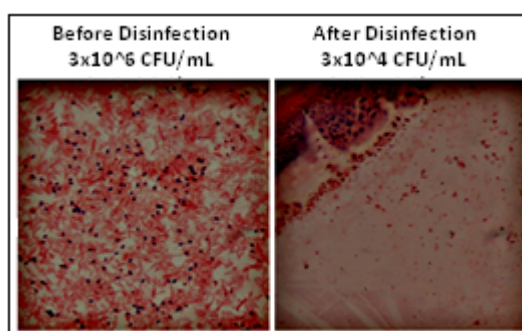

Figure 6 Visualization of bacteria experienced disinfection using a venturi injector

#### 4. CONCLUSION

Hydrodynamic cavitation is possible for the disinfection of the bacteria *E.coli*. The higher the initial concentration of bacteria, the longer the disinfection time. The orifice plate gave better disinfection results than the venturi injector. The ratio  $C/C_0$  using orifice plate on  $C_0 = 10^6$  CFU/mL was 0.00108 in 60 minutes, on  $C_0 = 10^5$  CFU/mL was 0 (zero) in 45 minutes, and on  $C_0 = 10^4$  CFU/mL was 0 (zero) in 20 minutes. While the ratio  $C/C_0$  using venturi injector on  $C_0$

=  $10^6$  CFU/mL was 0.01 in 60 minutes, on  $C_0 = 10^5$  CFU/mL was 0 (zero) in 60 minutes, and on  $C_0 = 10^4$  CFU/mL was 0 (zero) in 30 minutes.

## 5. ACKNOWLEDGEMENT

We thank Directorate of Research and Public Service Universitas Indonesia with the Grant of Hibah Riset Madya UI (RM-UI) 2012 for the financial support of this research.

## 6. REFERENCES

- Arrojo, S., Benito, Y., Tarifa, A.M., 2008. A Parametrical Study of Disinfection with Hydrodynamic Cavitation. *Ultrasonic Sonochemistry*, Volume 15, pp. 903-908.
- Balasundaram, B., Harrison, S.T.L., 2008. Study of Physical and Biological Factors Involved in the Disruption of *E.coli* by Hydrodynamic Cavitation. *Biotechnol Prog* 2006, Volume 22, pp. 907-913.
- Firmansyah, Ferry., 2009. Air Tanah Jakarta Semakin Tercemar Bakteri E-Coli. Available at: [http://www.tempointeraktif.com/hg/layanan\\_publik/2009/02/27/brk,20090227-162362, id.html](http://www.tempointeraktif.com/hg/layanan_publik/2009/02/27/brk,20090227-162362, id.html). (Access on 5 Oktober 2011)
- Gogate, P.R., Pandit, A.B., 2001. Hydrodynamic Cavitation Reactors: a State of the Art Review. Matunga: Division of Chemical Engineering, University Department of Chemical Technology, University of Mumbai.
- Gogate, Parag. R., 2007. Application of Cavitational Reactors for Water Disinfection: Current Status and Path Forward. *Journal of Environmental Management*, Volume 85, pp. 801–815.
- Ince N.H., Tezcanli, G., Belen, R.K., Apikyan, İ.G., 2001. Ultrasound as a Catalyzer of Aqueous Reaction Systems: The State of the Art and Environmental Application. *Environmental*. Volume 29, pp.167-176.
- Jyoti, K.K., Pandit, A.B., 2003. Hybrid Cavitation Methods for Water Disinfection: Simultaneous Use of Chemicals with Cavitation. *Ultrasonics Sonochemistry*. Volume 10, pp. 255–264.
- Mezule, L.S., Tsyfansky, V., Yakushevich, Juhna, T., 2009. A Simple Technique for Water Disinfection with Hydrodynamic Cavitation: Effect on Survival of Escherichia coli. *Desalination*, Volume 248, pp. 152-159.
- Save, S.S., Pandit, A.B., Joshi, J.B., 1997. Use of Hydrodynamic Cavitation for Large Scale Microbial Cell Disruption. *Trans IchemE*, Volume 75 Part C.
- Sawant, S.S., Anil, A.C., Krishnamurthy, V., Gaonkar, C., Kolwalkar, J., Khandeparker, L., 2008. Effect of Hydrodynamic Cavitation on Zooplankton: a Tool for Disinfection. *Biochemical Engineering Journal*, Volume 42, pp. 320-328.
- Sivakumar, Manickam., Pandit, Aniruddha, B., 2002. Wastewater Treatment : a Novel Energy Efficient Hydrodynamic Cavitational Technique. *Ultrasonic Sonochemistry*, Volume 9, pp. 123-131.
- Sururi, Moh. Rangga, Rachmawati, Solihah, Matina., 2008. Perbandingan Efektifitas Klor dan Ozon Sebagai Desinfektan pada Sampel Air dari Unit Filtrasi Instalasi PDAM Kota Bandung. Seminar Nasional Sains dan Teknologi-II.
- von Gunten, Urs., 2003a. Ozonation of drinking water: Part II. Disinfection and by-product formation in presence of bromide, iodide or chlorine. *Water Research*, Volume 37, pp. 1469-1487.
- von Gunten, Urs., 2003b. Ozonation of Drinking Water: Part I. Oxidation Kinetics and Product Formation. *Water Research*, Volume 37, pp. 1443-1467.
- USEPA, 1999. Wastewater Technology Fact Sheet Ozone Disinfecton. EPA 832-F-99-063